

Read all Instructions before beginning!!!!

Caution – **EXTREME DANGER** – Caution

Do not use or mix any other manufacturer's products with any Nitrous Express products.

Do not use or mix any Nitrous Express products with any other manufacturer's products.

THESE INSTRUCTIONS APPLY TO NITROUS EXPRESS PRODUCTS ONLY!

FOR SANCTIONED RACE USE ONLY - NOT FOR SALE OR USE IN CALIFORNIA

NX RPM ACTIVATED WINDOW SWITCH

PN 18959 & PN18959M

IMPORTANT: Read the instructions before attempting the installation

Parts Included:

1 - RPM Window Switch

1 - 3000 RPM Chip

1 - Electrical Pack

1 - 6000 RPM Chip

1 - Pigtail and Relay

NOTE: RPM Modules must be purchased separately.

The RPM Activate Window Switch can be connected to stock ignition systems or MSD Ignitions. When using a capacitive discharge ignition such as an MSD, **do not** connect the Switch to the coil negative terminal. Damage to the Switch will occur.

The Window Switch is capable of carrying 1.5 amps. If the circuit you are activating requires more current, an NX Relay, PN 15515 (Relay & Pigtail) or 15526 (Relay only) must be used.

The RPM Window Switch has a circuit that activates a device by providing a ground path at a desired rpm (Figure 1). The ground will be removed at a different rpm to deactivate the device. If no rpm module is installed the device will remain activated as long as the rpm is above the activation amount.

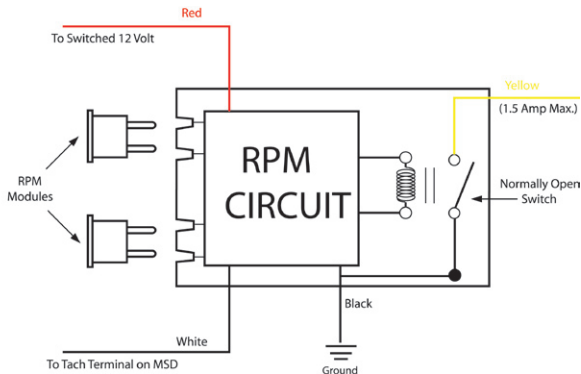

Figure 1 Operation of the RPM Window Switch

CYLINDER PROGRAMMING

The Window Switch is programmed for 8-cylinder applications, however it can be used with 4 or 6-cylinder applications. To program the Switch for different applications, the cylinder select loops must be modified as shown in Figure 2

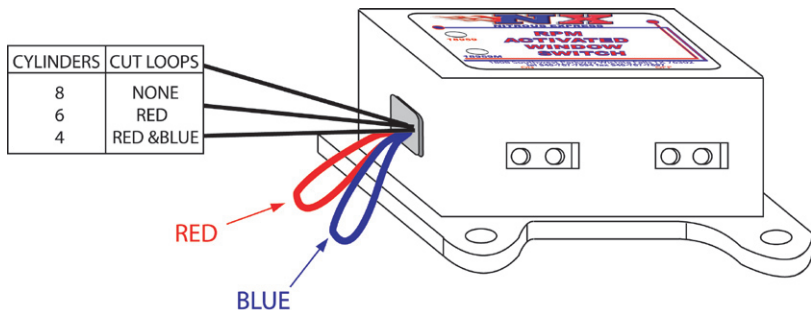

Figure 2 Cylinder Select Loops

MOUNTING

The Switch may be mounted under the hood as long as it is away from direct engine heat sources. Keep in mind that the rpm modules should be easy to access for changes. The Switch can be mounted with the double sided tape or with the 3 self tapping screws supplied. Use the Switch as a template and mark the mounting hole locations. Remove the Switch and drill the holes using a 3/16" drill bit then install the screws.

WIRING

Red	Connects to a switched 12 volt source
Black	Connects to ground
White	The rpm input wire. With an MSD Ignition, this connects to the Tach Output terminal. On inductive ignitions, connects to the coil negative terminal.
Yellow	This is the circuit ground wire (normally open switch to ground). It connects to the ground side of the device you plan to activate.

Figure 3 Wiring to an Inductive Ignition System

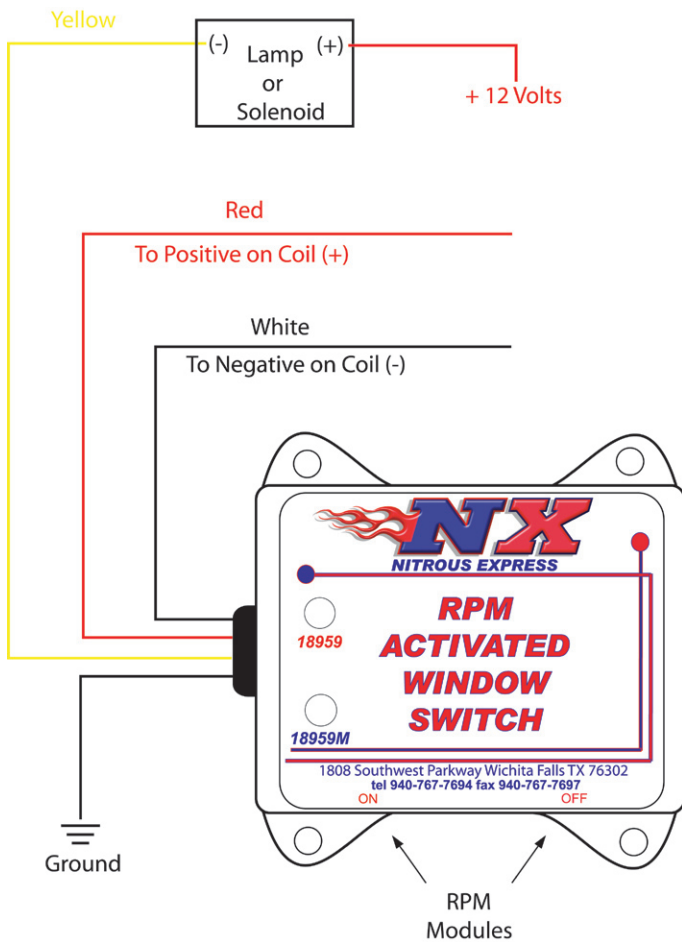

Figure 4 Wiring with an NX Relay

